

HIGHLAND

Dual Recycling Bin

CORBY

METAL INSERTS WITH HANDLES
Easy to use



LUXURY PU LEATHER FINISH

SUPPLIED WITH INTERNATIONAL RECYCLE STICKERS



RAISED PLASTIC FEET

- PU leather
- Durable construction
- Raised plastic feet
- Supplied with metal recycling insets



Specification

Black
3.85kg
6L + 6L

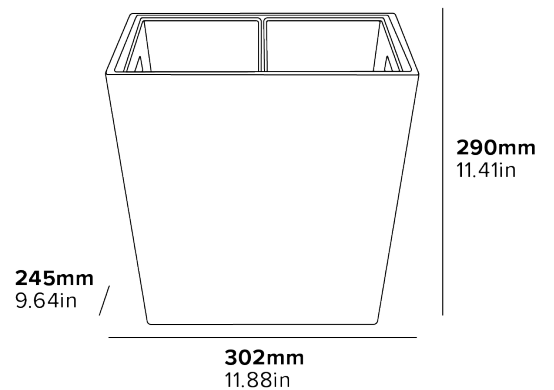

HIGHLAND

Dual Recycling Bin

CORBY



ABOUT THIS PRODUCT

The Highland Dual Recycling Bin in black is a premium, luxury solution for stylish and sustainable waste management. Expertly wrapped in high-quality PU leather, it brings an elegant, sophisticated finish to any interior. Designed with durability in mind, this bin features dual sleek metal compartments (6L + 6L) for effortless recycling, while raised feet provide stability and protect surfaces. The Highland Dual Recycling Bin offers an organised, eco-conscious approach without compromising on style.